

Titantec®

MAKE LIFE MORE BEAUTIFUL

TT-GD620T-3

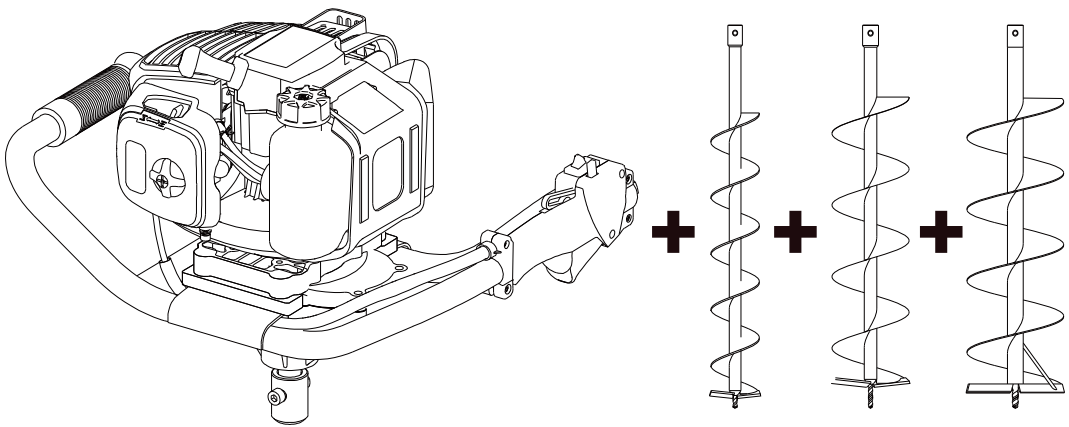

DEAR CUSTOMER



In order to achieve the best performance of your product, please read this instruction manual carefully before using, and keep it for future reference.



SAFETY FIRST

Instructions contained in warnings within this manual marked with a  symbol concern critical points which must be taken into consideration to prevent possible serious bodily injury, and for this reason you are requested to read all such instructions carefully and follow them without fail.

■ WARNINGS IN THE MANUAL

WARNING

This mark indicates instructions which must be followed in order to prevent accidents which could lead to serious bodily injury or death.

IMPORTANT

This mark indicates instructions which must be followed, or it leads to mechanical failure, breakdown, or damage.

NOTE

This mark indicates hints or directions useful in the use of the product.

CONTENTS

1. Parts location	3
2. Specifications	4
3. Symbols on the machine	4
4. Warning labels on the machine.....	5
5. For safe operation	6
6. Fuel.....	11
7. Operation	12
8. Maintenance	14
9. Storage	15
10. Troubleshooting guide.....	16

1. Parts location

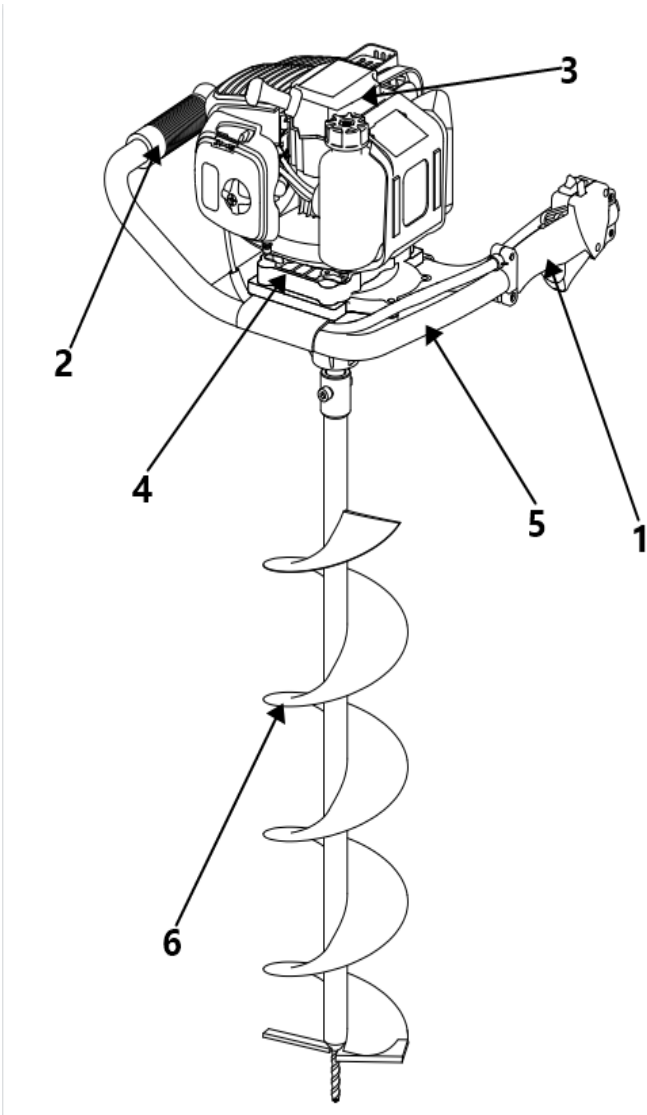

1. Throttle Assy

4. Gear transmission

2. Left Handle

5. Frame

3. Engine Assy

6. Driller (optional)

2. Specification

Model number	TT-GD620T-3
Engine type	TT-1E47.5F(air-cooled, 2-stroke)
Engine displacement	62 CC
Maximum engine power	2.6kw/8500rpm
Engine Max speed	10000 min ⁻¹
Engine idling speed	3000±300 min ⁻¹
Fuel Mixture	Petrol 25 : Oil 1
Volume of fuel tank	1000 ml
Starter	Recoil
Spark plug	TORCH L8RTF
Carburetor	Diaphragm type
Weight(without driller and petrol)	9.0 kg
Tested sound pressure level, L _{PA} (2000/14/EC)	L _{PA} : 107.7 dB(A), k=3 dB(A)
Guaranteed sound power level, L _{WA} (2000/14/EC)	L _{WA} : 113 dB(A), k=3 dB(A)
Vibration level	21.206m/s ² , K=1.5 m/s ²
Max driller speed	300 min ⁻¹
Driller size	(φ 60~φ 300)MM*80CM
Standard Driller	φ 100MM, φ 150MM, φ 200MM
Gear box lubricant	Gear oil SAE#80-90

Note: Specifications are subject to change without notice.

3. Symbols on the machine

For safe operation and maintenance, symbols are carved in relief on the machine. According to these indications, please be careful not to make a mistake.

For safe operation and maintenance, symbols are carved in relief on the machine. According to these indications, please be careful not to make a mistake.

CHOKE OPERATION



Starting mode when the engine is hot (choke off).

Position: AIR CLEANER COVER



Starting mode when the engine is cold (choke on).

Position: AIR CLEANER COVER

4. Warning labels on the machine

	<p>WARNING! Improper Condition Can Cause Serious Injury</p>		<p>Don't work under raining days.</p>
	<p>Read the instruction manual completely and carefully before using the power tool.</p>		<p>Don't smoke or allow flames on the machine</p>
	<p>Wear hearing protection!</p>		<p>Danger of hot components</p>
	<p>Wear safety glasses!</p>		<p>Wear protective gloves.</p>
	<p>Wear safety footwear</p>		<p>The guaranteed noise level</p>

! IMPORTANT

If warning label peel off or become soiled and impossible to read, you should contact the dealer from which you purchased the product to order new labels and affix them in the required location(s).

! WARNING

Never modify your product. We won't warrant the machine, if you use the remodeled brush cutter or you don't observe the proper usage written in the manual.

5. For safe operation

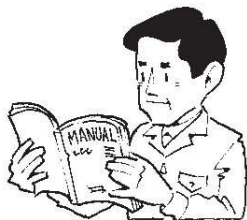

1. Read this manual carefully until you completely understand and follow all safety and operating instructions.

2. Keep this manual handy so that you may refer to it later whenever any questions arise. Also note, if you have any questions which cannot be answered herein, contact the dealer from whom you purchased the product.

3. Always be sure to include this manual when selling, lending, or otherwise transferring the ownership of this product.

4. Never allow children or anyone unable to fully understand the directions given in the manual to use the machine.



■ WORKING CONDITION

1. When using the product, you should wear proper clothing and protective equipment.

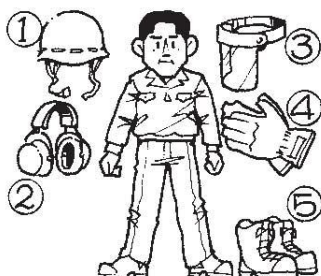

(1) Helmet

(2) Ear protectors

(3) Protection goggles or face protector

(4) Thick work gloves

(5) Non-slip-sole work boots

2. And you should carry with you.

(1) Attached tools and files

(2) Properly reserved fuel

(3) Spare blade

(4) Things to notify your working area (rope, warning signs)

(5) Whistle (for collaboration or emergency)

(6) Hatchet or saw (for removal of obstacles)



3. Do not wear loose clothing, jewelry, short trousers, sandals, or go barefoot. Do not wear anything which might be caught by a moving part of the unit. Secure hair so it is above shoulder length.

■ WORKING CIRCUMSTANCE

1. Never start the engine inside a closed room or building. Exhaust gases contain dangerous carbon monoxide.

2. Never use the product,
a. when the ground is slippery or when you can't maintain a steady posture.

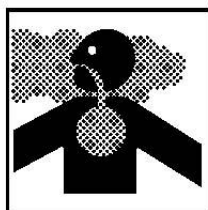

5. For safe operation

b. At night, at times of heavy fog, or at any other times when your field of vision might be limited and it would be difficult to gain a clear view of the working area.

c. During rain storms, during lightning storms, at times of strong or gale-force winds, or at any other times when weather conditions might make it unsafe to use the product.



■ WORKING PLAN

1. You should never use the product when under the influence of alcohol, when suffering from exhaustion or lack of sleep, when suffering from drowsiness as a result of having taken cold medicine or at any other time when a possibility exists that your judgment might be impaired or that you might not be able to operate the product properly and in a safe manner.

2. When planning your work schedule, allow plenty of time to rest. Limit the amount of time over which the product is to be used continuously to somewhere around 30~40 minutes per session, and take 10~20 minutes of rest between work sessions. Also try to keep the total amount of work performed in a single day under 2 hours or less.

▲ WARNING

1. If you don't observe the working time, or working manner (See ■ USING THE PRODUCT), Repetitive Stress Injury (RSI) could occur. If you feel discomfort, redness and swelling of your fingers or any other part of your body, see a doctor before getting worse.
- 2.
3. To avoid noise complaints, in general, operate product between 8a.m. and 5p.m. on weekdays and 9a.m. to 5p.m. weekends.

📖 NOTE

Check and follow the local regulations as to sound level and hours of operations for the product.

■ BEFORE STARTING THE ENGINE

1. The area within a perimeter of 50 feet (15m) of the person using the product should be considered a hazardous area into which no one should enter. If necessary, yellow warning rope, warning signs should be placed around the perimeter of the area. When work is to be performed simultaneously by two or more persons, care should also be taken to constantly look around or otherwise check for the presence and locations of other people working so as to maintain a distance between each person sufficient to ensure safety.

5. For safe operation

2. Check the condition of working area to avoid any accident by hitting hidden obstacles such as stumps, stones, cans, or broken grass.

⚠ IMPORTANT

Remove any obstacle before beginning work.

3. Inspect the entire unit for loose fasteners and fuel leakage. Make sure that the driller is properly installed and securely fastened.

■ STARTING THE ENGINE

1. Keep bystanders and animals at least 50feet (15m) away from the operating point. If you are approached, immediately stop the engine.

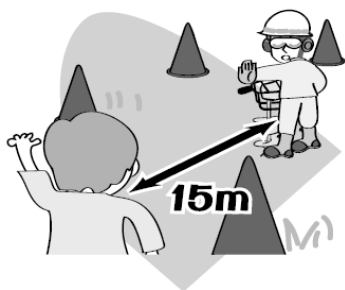

2. The product is equipped with a centrifugal clutch mechanism, so the driller begins to rotate as soon as the engine is started by putting the throttle into the start position. When starting the engine, place the product onto the ground in a flat clear area and hold it firmly in place so as to ensure that neither the driller nor the throttle come into contact with any obstacle when the engine starts.

⚠ WARNING

Never place the throttle into the high speed position when starting the engine.

3. After starting the engine, check to make sure that the cutting attachment stops rotating when the throttle is moved fully back to its original position. If it continues to rotate even after the throttle has been moved fully back, turn off the engine and take the unit to your authorized servicing dealer for repair.

■ USING THE PRODUCT

⚠ IMPORTANT

Drill only materials recommended by the manufacturer. And use only for tasks explained in the manual.

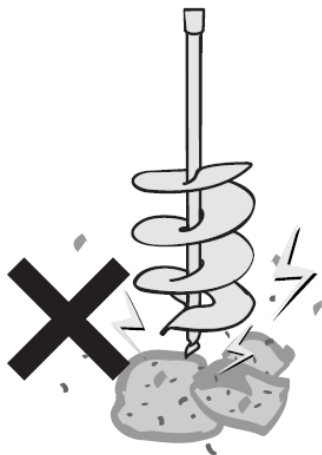

1. Grip the handles firmly with both hands using your whole hand. Place your feet slightly apart (slightly further apart than the width of your shoulders) so that your weight is distributed evenly across both legs, and always be sure to maintain a steady, even posture while working.

2. Maintain the speed of the engine at the level required to perform drilling work, and never raise the speed of the engine above the level necessary.

5. For safe operation



3. If the unit start to shake or vibrate, turn off the engine and check the whole unit. Do not use it until the trouble has been properly corrected.

5. Keep all parts of your body away from rotating cutting attachment and hot surfaces.

6. Never touch the muffler, spark plug, or other metallic parts of the engine while the engine is in operation or immediately after shutting down the engine. Doing so could result in serious burns or electrical shock.

• IF SOMEONE COMES

1. Guard against hazardous situations at all times. Warn adults to keep pets and children away from the area. Be careful if you are approached. Injury may result from flying debris.

2. If someone calls out or otherwise interrupts you while working, always be sure to turn off the engine before turning around.

■ MAINTENANCE

1. In order to maintain your product in proper working order, perform the maintenance and checking operations described in the manual at regular intervals.

2. Always be sure to turn off the engine before performing any maintenance or checking procedures.

WARNING

The metallic parts reach high temperatures immediately after stopping the engine.

3. Under no circumstances should you ever take apart the product or alter it in any way. Doing so might result in the product becoming damaged during operation or the product becoming unable to operate properly.

■ HANDLING FUEL

1. The engine of the product is designed to run on a mixed fuel which contains highly flammable gasoline. Never store cans of fuel or refill the tank of the unit in any place where there is a boiler, stove, wood fire, electrical sparks, welding sparks, or any other source of heat or fire which might ignite the fuel.

2. Never smoke while operating the unit or refilling its fuel tank.

5. For safe operation

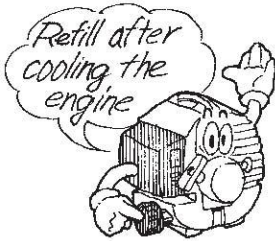

3. When refilling the tank, always turn off the engine and allow it to cool down. Take a careful look around to make sure that there are no sparks or open flames anywhere nearby before refueling.

4. Wipe spilled fuel completely using a dry rag if any fuel spillage occurs during refueling.

5. After refueling, screw the fuel cap back tightly onto the fuel tank and then carry the unit to a spot 10feet (3m) or more away from where it was refueled before turning on the engine.

■ TRANSPORTATION

1. When hand-carrying the product, cover over the cutting part if necessary, lift up the product and carry it paying attention to the blade.

2. Never transport the product over rough roads over long distances by vehicle without removing all fuel from the fuel tank. If doing so, fuel might leak from the tank during transport.

6. Fuel



⚠ WARNING

- Gasoline is very flammable. Avoid smoking or bringing any flame or sparks near fuel.
- Wipe up all spills before starting the engine.
- Make sure to stop the engine and allow it cool before refueling the unit.
- Keep open flames away from the area where fuel is handled or stored.

⚠ IMPORTANT

- Never use oil for 4 cycle engine use or water cooled 2-cycle engine.
- Never use "FUEL WITH NO OIL (RAW GASOLINE)".
- Never use fuel laced with water.
- Mixed fuels which have been left unused for a period of one month or more may clog the carburetor or result in the engine failing to operate properly. Put remained fuel into an air-tight container and keep it in the dark and cool room.
- Please ask for "mixed gasoline for air-cooled 2-cycle engines" at your nearest gas station, or use fuel made by putting unleaded gasoline for automobiles and air-cooled 2-cycle engine oil into a mixing container in accordance with the following ratios and then shaking to mix well.

Mixing ratios:



When using commercially available 2-cycle oil (FB grade):

25:1

(160 ml of oil for every 4 liters of gasoline)

■ HOW TO MIX FUEL

1. Measure out the quantities of petrol and oil to be mixed.
2. Put some of the petrol into the clean, approved fuel container supplied.
3. Pour in the oil and agitate well.
4. Be careful that, if the agitation is insufficient, there is an increased danger of early piston seizing due to abnormally lean mixture.

■ FUELING THE UNIT

1. Untwist and remove the fuel cap. Rest the cap on a dustless place.
2. Pour fuel into the fuel tank to 80% of the full capacity.
3. Fasten the fuel cap securely and wipe up any fuel spillage around the unit.

⚠ WARNING

1. Select bare ground for fueling.
2. Move at least 10ft (3m) away from the fueling point before starting the engine.
3. Stop the engine before refueling the unit. At that time, be sure to sufficiently agitate the mixed petrol in the container.
4. In the case of storing the product for a long period of time, clean the fuel tank after rendering it empty. Next, activate the engine and empty the carburetor of the composite fuel.

7. Operation

■ INSTALLING DRILLER

1. Put the driller (2) onto the drive shaft (1) of the auger.
2. Secure the driller (2) with the screw (3) and the nut (4), tighten them.

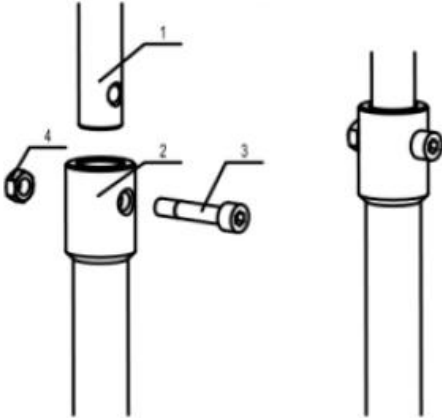

■ STARTING ENGINE



WARNING

The driller will start rotating upon the engine starts.

1. Feed fuel into the fuel tank and tighten the cap securely.
2. Rest the unit on a flat, firm place. Keep the driller off the ground and clear of surrounding objects as it will start rotating upon starting of the engine.
3. Push the primer pump several times until overflowed fuel flows out in the return tube.

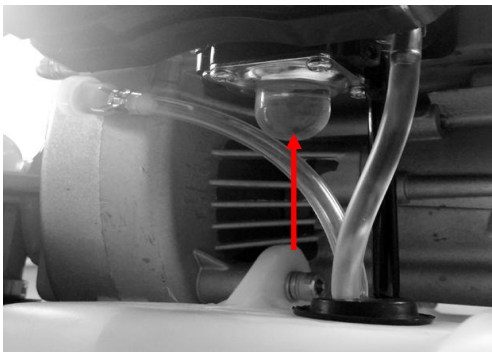

4. Move the choke lever to the OFF position.

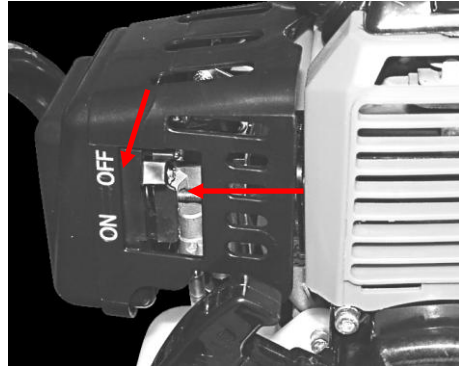

5. Set the ignition switch to the "ON" position.

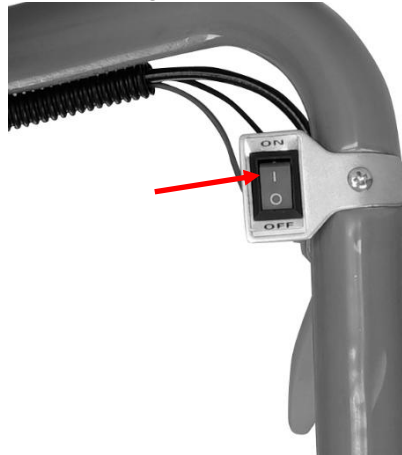

6. Place the unit on a flat, firm place. While holding the unit firmly, pull out the starter rope quickly until engine fires.

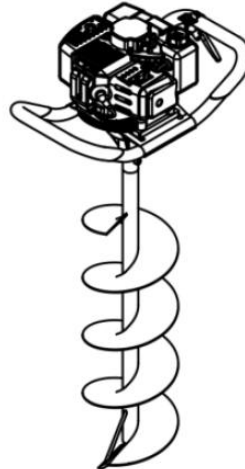

⚠ IMPORTANT

- Avoid pulling the rope to its end or returning it by releasing the knob. Such actions can cause starter failures.

7. Operation

7. Move the choke lever to the ON position. And pull out the starter rope quickly to restart engine.

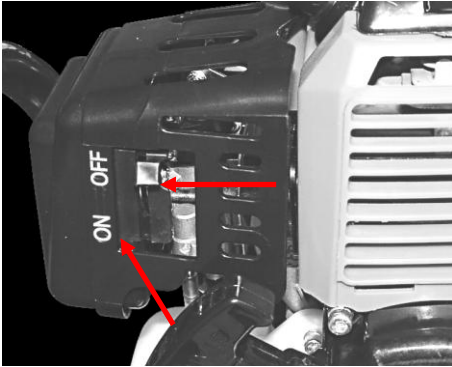

8. Allow the engine to warm up for several minutes before starting operation.

NOTE

1. When restarting the engine immediately after stopping it, leave the choke at ON position.
2. Overchoking can make the engine hard to start due to excess fuel. When the engine failed to start after several attempts, open the choke and repeat pulling the rope, or remove the spark plug and dry it.

■ STOPPING ENGINE

1. Release the throttle lever and run the engine for a half minute.
2. Shift the ignition switch to the OFF position.



NOTE

- Except for an emergency, avoid stopping the engine while pulling the throttle lever.

■ ADJUSTING IDLING SPEED (

1. When the engine tends stop frequently at idling mode, turn the adjusting screw clockwise.
2. When the cutting head keeps rotating after releasing the trigger, turn the adjusting screw

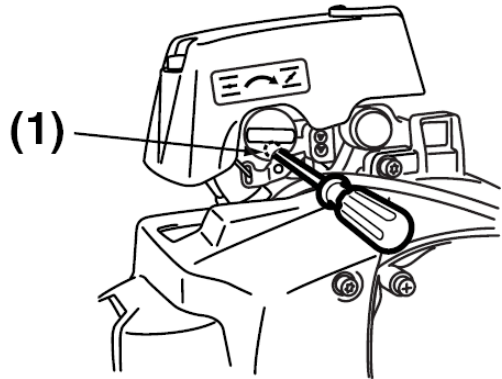

(1) Idle speed adjuster

NOTE

- Warm up the engine before adjusting the idling speed.

■ DRILLING

- Keep a firm grip of the auger at all times on a wide stance and by holding the handle with both hands.
- A reacting motion may occur on the auger when spinning drill has hit on stones or tree roots under the ground. Always hold the auger securely to control such motion.
- Start drilling with half-throttle, and gradually increase the engine speed so that the drill may get into the ground smoothly.
- When the drill has been caught in the ground and cannot be pulled out, stop the engine and rotate the auger counter-clockwise.



8. Maintenance

MAINTENANCE CHART

System/components	Procedure	Before use	Every 25 hours after	Every 50 hours after	Every 100 hours after	Note
fuel leaks, fuel spillage	wipe out	✓				
fuel tank, air filter, fuel filter	inspect/clean	✓	✓			replace, if necessary
idle speed adjuster	see adjusting idling speed	✓				replace carburetor if necessary
spark plug	clean and readjust plug gap			✓		GAP: .025 in (0.6 ~ 0.7 mm) replace, if necessary
intake air cooling vent	clean		✓			
throttle trigger, stop switch	check operation	✓				
Pump inlet valve	replace if something's wrong	✓				
screws/nuts/bolts	tighten/replace	✓			✓	not adjusting screws

- Before cleaning, inspecting, or repairing the unit, make sure that the engine has stopped and is cool.
- Use protective gloves whenever inspecting, removing and installing the drill.

⚠ WARNING

- Always be sure to stop the engine before inspecting the brush cutter for problems or performing maintenance.
- Never alter the auger or take the engine apart.

■ AIR FILTER

- The air filter, if clogged, will reduce the engine performance. Monthly check and clean the filter element in warm, soapy water as required. Dry completely before installing. If the element is broken or shrunk, replace with a new one.

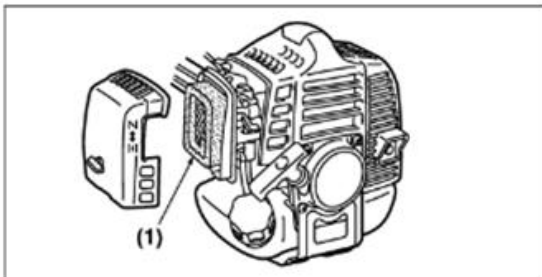

(1) Air filter

■ FUEL FILTER

- When the engine runs short of fuel supply, check the fuel cap and the fuel filter for blockage.

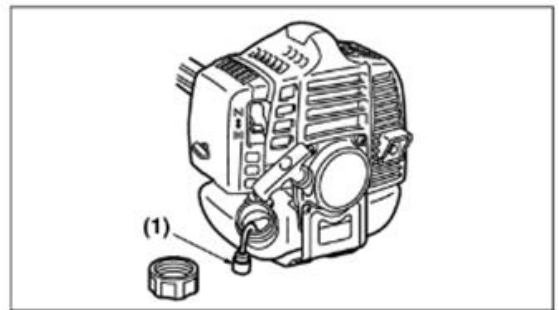

(1) Fuel filter

- If the fuel filter is clogged, the engine speed may be limited or speed fluctuations may occur.
- If the engine is operated without a fuel filter, dirt will accumulate in the carburetor and cause damage.

■ SPARK PLUG

- Starting failure and mis-firing are often caused by a fouled spark plug. Periodically clean the spark plug and check that the spark gap is in the correct range.
- When you take off the spark plug, twist and pull off the cap.
- The correct electrode is 0.6~0.7mm.

8. Maintenance

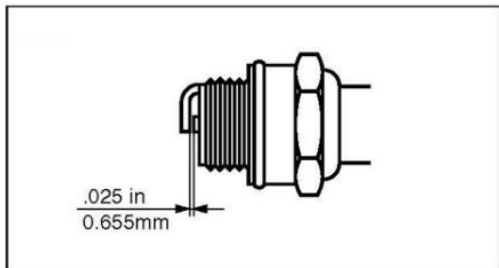

⚠ IMPORTANT

- Note that using any spark plugs other than those designated may result in the engine failing to operate properly or in the engine becoming overheated and damaged.
- To install the spark plug, first turn the plug until it is finger tight, then tighten it a quarter turn more with a socket wrench.

TIGHTENING TORQUE: 9.8~11.8 N.m

■ MUFFLER

⚠ WARNING

- Inspect periodically, the muffler for loose fasteners, any damage or corrosion. If any sign of exhaust leakage is found, do not use the brush cutter and have it repaired immediately.
- Note that failing to do so may result in the engine catching on fire.

■ INTAKE AIR COOLING VENT

- Check the intake air cooling vent and the area around the cylinder cooling fins after every

9. Storage

⚠ WARNING

- Aged fuel is one of major causes of engine starting failure.
1. Drain a fuel tank and push the primer bulb until it becomes empty of fuel.
 2. Remove the spark plug and drop a spoonful of 2-cycle oil into the cylinder. Crank the engine several times and replace the plug.
 3. Brush off dirt from the drill surface and apply rust protective oil.
 4. Store the machine in a dry, dust-free place.

25 hours of use for blockage, and remove any waste which has attached itself to the brush cutter. Note that it is necessary to remove the plug guard shown in Figure in order to be able to view the upper part of the cylinder.

⚠ IMPORTANT

- If waste gets stuck and causes blockage around the intake air cooling vent or between the cylinder fins, it may cause the engine to overheat, and that in turn may cause mechanical failure on the part of the brush cutter.

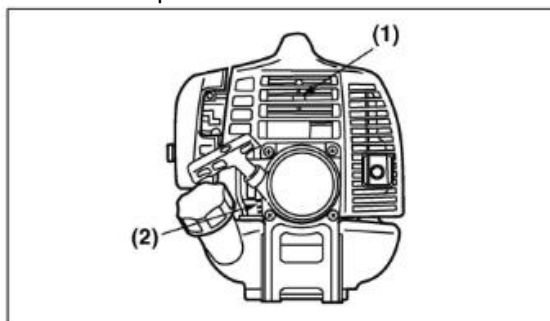

(1) Cylinder fin

(2) Intake air cooling vent (back)

■ DRILLER

- Make sure to use the sharp driller.
- Replace if the bit or the tip is worn and the driller may not get into the object smoothly.

10. Troubleshooting guide

Case 1. Starting failure

CHECK	PROBABLE CAUSES	ACTION
fuel tank	→ incorrect fuel	→ drain it and use correct fuel
fuel filter	→ fuel filter is clogged	→ clean
carburetor adjustment screw	→ out of normal range	→ adjust to normal range
spark plug	→ spark plug is fouled/wet	→ clean/dry
	→ plug gap is incorrect	→ correct (GAP: 0.6~0.7mm)
	→ disconnected	→ re-tighten

Case 2. Engine starts but does not keep running/Hard re-starting.

CHECK	PROBABLE CAUSES	ACTION
fuel tank	→ incorrect fuel or staled fuel	→ drain it and with correct fuel
carburetor adjustment screw	→ out of normal range	→ adjust to normal range
muffler,cylinder (exhaust port)	→ carbon is built-up	→ wipe away
air cleaner	→ clogged with dust	→ air blow or wash
cylinder fin, fan cover	→ clogged with dust	→ clean

When your unit seems to need further service, please consult with service shop in your area.